

DOI: 10.12731/2227-930X-2017-2-64-73

UDC 37.02

## IMITATING MODEL OF ASSIMILATION AND FORGETTING OF THE LOGICALLY CONNECTED INFORMATION

*Mayer R.V.*

*The educational material we present as a set of a number of information blocks consisting of learning material elements (LMEs); therefore its assimilation and forgetting occurs differently, than in the Ebbinghaus's experiments. The purpose of the article is constructing of a computer model of assimilation and forgetting of the logically connected information allowing: 1) to prove the fast rise of understanding while training; 2) to receive the forgetting curve for the comprehended information. The modeling methods help to receive the graphs of the knowledge level dependence on time. It is shown, that the processes of assimilation and forgetting occurs according to the logistic law.*

**Keywords:** didactics; training, mastering; forgetting; computer modeling; level of knowledge; information block.

## ИМИТАЦИОННАЯ МОДЕЛЬ УСВОЕНИЯ И ЗАБЫВАНИЯ ЛОГИЧЕСКИ СВЯЗАННОЙ ИНФОРМАЦИИ

*Майер Р.В.*

*Учебный материал представим в виде совокупности большого числа информационных блоков, состоящих из элементов учебного материала (ЭУМ), поэтому его усвоение и забывание происходит иначе, чем в опытах Эббингауза. Цель статьи состоит в построении компьютерной модели усвоения и забывания логически связанной информации, позволяющей: 1) обосновать скачок понимания в процессе обучения; 2) получить кривую забывания для осмысленной*

*информации. Методами моделирования получены графики зависимости уровня знаний от времени. Показано, что процессы усвоения и забывания происходят по логистическому закону.*

**Ключевые слова:** *дидактика; обучение; усвоение; забывание; компьютерное моделирование; уровень знаний; информационный блок.*

### Introduction

The learning efficiency strongly depends on the pupil's perception, understanding, memorizing and forgetting of the reported information [1]. The regularities of these processes are studied by experimental psychology [2]. The fundamental research in this area is the work by Ebbinghaus (1885), devoted to the study of laws of storing (memorizing) without participation of the thinking processes, in which the method of learning senseless syllables exciting no semantic associations was used. It is impossible to name knowledge received by the pupil at a lesson, as the senseless information; it is easily associated with concepts, laws and theories, which the schoolchild already has got. S.L. Rubinstein marks, that forgetting of the comprehended material is not described by the Ebbinghaus's curve; this process submits to different laws and happens considerably slower [2, p. 136].

The purpose of the article is in creation and substantiation of the model of assimilation and forgetting of the logically connected information corresponding to the following facts: 1) during training there is a qualitative fast growth as a result of which the pupil suddenly begins understanding the material being studied; 2) often the pupil is not able to recall the specific learning material element (LME) directly, but he can recall it by association or logically deduce it from the LMEs known to him; 3) after the end of training if the pupil does not use the received knowledge, the reverse leap occurs: the comprehension level of the studied problem remains high at first, and then decreases. In the research the mathematical and computer simulation methods are used. The offered simulation model of assimilation and forgetting is based on the works by R. Atkinson, G. Bauer and E. Kroters [3],

R. Bush and T. Mosteller [4], D. Gibson and P. Jakl [5], L.P. Leontyev and O.G. Gohmann [6], F.S. Roberts [7], A.P. Sviridov [8], Hunt E. [9], and is the development of the approach stated in the papers by R.V. Mayer [10–13].

### **Constructing of matrix model of mastering**

While studying the logically connected material the pupil not only tries to remember a set of separate LMEs (concepts, formulas), he tries to acquire the sequence of reasonings. The important condition of fast and strong assimilation of the reported information is its understanding, that is inclusion of any new facts, ideas and theories into the system of knowledge and representations that the pupil has, making connections with the acquired information [1, 2]. The essence of the offered approach is that the educational material is considered as a set of  $N$  separate ideas or information blocks. Each block consists of  $M$  learning material elements (LMEs), ordered and connected with logic links. To understand any new idea the pupil should solve the given intellectual problem, that is to study a sequence of all LMEs, included into the structure of the given information block, in first time. When the schoolchild has acquired all LMEs of the given idea and, solving the educational task, again goes through their sequence, in second (fifth or tenth) time he turn to the concrete cognitive situation. This happens without active involvement of thinking and is called understanding-recollection.

Knowledge of the given  $(i,j)$  – LME is defined by probability  $p_{i,j}$  of the correct answer to the corresponding elementary question (fig. 1). The probability of the specific idea reproduction by the pupil is equal to the product of the all LMEs reproduction probabilities making this idea. Each LME is connected to some LMEs from some other ideas (blocks). For the simplicity it is possible to imagine a two-dimensional array of  $N$  lines and the  $M$  columns in which each element corresponds to probability  $p_{i,j}$  of the corresponding LME remembering and is connected with four nearby LMEs (fig. 1). The links degree is defined by coefficients  $c_{i,j}$ .

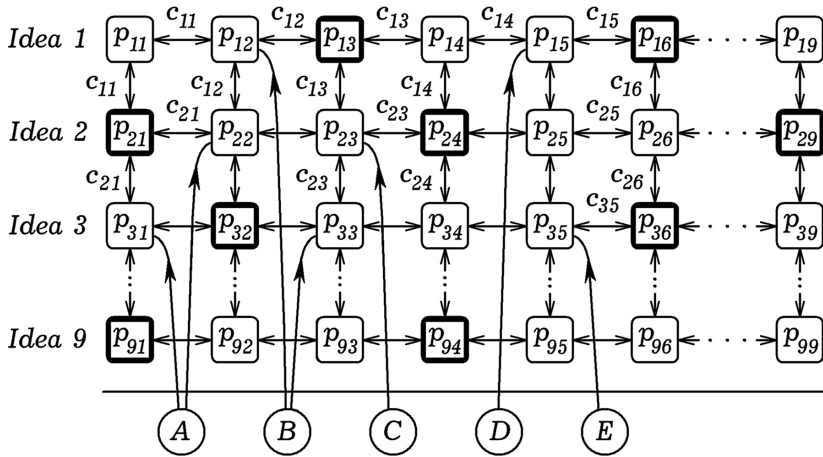
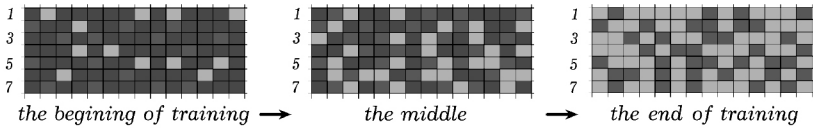

Fig. 1. The comprehended information as a system of  $N$  chains of the  $L$  LMEs

We characterize the studied material by: 1) the amount of the ideas (LMEs chains); 2) the average length of ideas  $L$ ; 3) the proportion  $D$  of LMEs known to the pupil a priori, that is before training; 4) the average coefficient of assimilation  $a$ . All LMEs can be divided into two categories: 1) well-known to the pupil; the probability of the correct answer for them is  $p_{i,j}=1$ ; 2) poorly-known to the pupil before the beginning of training,  $p_{i,j}=0-0,1$ . Fig. 1 shows the first, second, third and ninth information blocks; LMEs of the first category (which are well-known to the pupil before training) are bold-framed. Each LME is connected with other LMEs (coefficient  $c_{ij}$  of some links can be equal to 0), and also with LMEs A, B, C, D, E which don't enter into structure of these logical reasoning chains. These links with external LMEs lead to increase in the assimilation coefficient  $a_{i,j}$  of the given LME; it can be taken into account, taking  $a_{i,j}$  from some interval in a random way.

Let us represent the poorly acquired LMEs ( $a_{i,j} < 0,33$ ) in dark blue color, well acquired LMEs ( $a_{i,j} > 0,67$ ) – in red, and all other LMEs – in green color (fig. 2). While training the average value  $p$  for all LMEs grows, blue sections turn into green and green sections – into red. The more red and green sections in the line (information block), the higher

the probability that the pupil has acquired this information block and will manage to do the corresponding sequence of reasonings. The more ideas the pupil has acquired, the bigger the probability of reproduction of all training material.



**Fig. 2.** Changes of the LMEs matrix while training

It is important that the knowledge of one LME leads to easier assimilation and remembering of an other related LMEs. While training probabilities  $p_{ij}$  and the link coefficients  $c_{ij}$  increase: the pupil reproduces all sequence of reasonings (all information block) easily. To consider the fact that some LMEs are well-known to the pupil before training, the matrix  $d_{ij}$  is created where elements with the given probability  $D$  are equal to 1, and with probability  $(1-D)$  – to zero. Let us take that while training the pupil carry out the sequence of the same educational tasks, consistently reproducing the idea after the idea, LME after another LME. It is known that while studying any logically connected material, the knowledge of one LME helps the pupil to study or recollect knowledge of another related LME. When studying  $j$ -th LME from the  $i$ -th idea within time  $\Delta t$ , the probability of the correct pupil's answer to the corresponding elementary question according to the law:

$$p_{ij}^{k+1} = p_{ij}^k + \alpha(1 - p_{ij}^k)\Delta t + c_{i,j}(p_{i,j-1}^k + p_{i,j+1}^k + p_{i-1,j}^k + p_{i+1,j}^k)\Delta t.$$

Here  $c_{ij}$  is the coefficient of links allowing to note influence of other LMEs on assimilation of  $(i,j)$  – LME,  $k$  – the step number. For simplicity sake we consider all link coefficients identical and constant. The model considers that in the process of the knowledge level growing the pupil's operating time with  $(i,j)$  – LME decreases, aspiring to  $\Delta t$ . If at the given moment the pupil doesn't operate with  $(i,j)$  – LME, then owing to forgetting the knowledge of this LME within time  $\Delta t$  decreases according to the exponential law. The average value of probabilities  $p_{ij}$  for all LMEs in moment  $t$  is labeled as  $p(t)$ .

For an estimation of the pupil's knowledge and making the graph  $Z(t)$  it is necessary to simulate the repeated periodic "testing" of the pupil at regular intervals. The pupil's knowledge of the  $i$ -th idea is determined as follows. The computer simulates the pupil's answer, in which he consecutively states the 1-st LME, the 2-nd LME ..., the  $L$ -th LME of the  $i$ -th chain (information block) during the given time.

The correct answer to the question corresponding the  $j$ -th LME from the  $i$ -th idea, is simulated as a casual process occurring to the probability  $p_{i,j}$ : the random variable  $x$  from the interval  $[0,1]$  is generated and the condition  $x < p_{ij}^k + a(1 - p_{ij}^k)\Delta t + c(p_{i,j-1}^k + p_{i,j+1}^k + p_{i-1,j}^k + p_{i+1,j}^k)$  is checked. If the condition is true, it is considered, that the pupil has answered correctly, and if it is false – not correctly. In case of the wrong answer the pupil tries to reproduce the  $(i,j)$ -LME again, and in the case of the correct – he passes to the next LME from the same idea. If all  $L$  LMEs of the  $i$ -th chain are done correctly within the answering time  $\tau=1,3L\Delta t$ , it is considered, that the schoolchild knows the  $i$ -th information block. The pupil's knowledge quantity  $Z(t)$  is equal to the number of ideas (information blocks), which he can reproduce. At such "testing" the schoolchild's knowledge does not increase, the probabilities  $p_{i,j}$  remain constant. For this modeling the program in Free Pascal is used.

### Results of modeling and their discussion

Let us take that before training 10% of all LMEs are known to the pupil, that is  $D=0,1$ , their level of knowledge is  $q=const$ . The fig. 3 shows the results of modeling of assimilation and forgetting of the logically connected information in two cases: 1) there are no connections between LMEs (with  $c=0$ ,  $a=1,6$ ); 2) LMEs are connected with each other ( $0 < c < 1$ ,  $a=0,4$ ). From results of modeling it follows: 1) even with no connections between LMEs the training leads to smooth increasing of  $p_{i,j}$ , that causes sharp rise of understanding  $Z(t)$  educational material; 2) presence of connections with constant link coefficient  $c$  raises the probability of reproduction of the learned material by the pupil; the graph  $p(t)$  bends in the other way, the advance  $Z(t)$  is greater; 3) after the termination of training the average level of mastering

of studied LMEs decreases according to an exponential law, but the knowledge level of the educational material at first practically does not decrease, then quickly reduces. If to take into account, that while training the connection coefficient  $c_{ij}$  grows, the transition from ignorance to knowledge is be sharper.

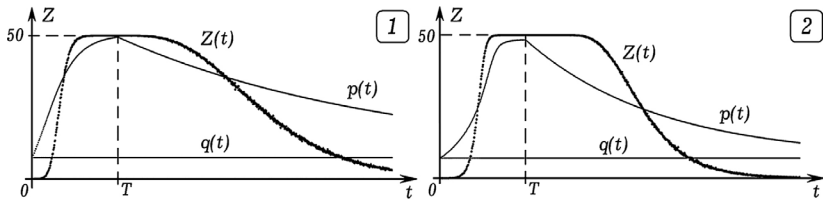

**Fig. 3.** The results of computer modeling of assimilation and forgetting

The sharp rise of understanding is caused by the fact that the training material consists of the ideas (or information blocks), each of which contains the  $L$  number of LMEs. To reproduce the concrete idea, the pupil has to acquire all LMEs entering it; to acquire all training material he should learn to reproduce all ideas. Joint studying of LMEs, included in the given information block, leads to sharp increase in probability of its reproduction. Increase in the link degree between various LMEs promotes their easier storing (memorizing) and reproduction.

### Conclusion

The article shows the model of studying of the LMEs logically connected system that allows to explain: 1) the sharp rise of the understanding level of the studied problem happening in the course of training; 2) the lowering of the pupil's knowledge level in consequence of gradual forgetting of separate LMEs. Assimilation and forgetting of the logical connected information can be described by the logistic law: 1) assimilation:  $dZ/dt = \alpha(I_0 - Z)Z$ , where  $I_0$  – the number of information blocks in educational material; 2) forgetting:  $B = Z^0/100$ ,  $x^0 = 100$ ,  $dx/dt = -\gamma(100,5 - x)x$ ,  $Z(t) = B \cdot x(t)$ . Increase in the knowledge level of all LMEs takes to understanding of all information blocks; the forgetting of at least one LME causes the pupil's inability to solve the correspond-

ing problem. Some time after the end of training the knowledge level remains high, and then, in the process of forgetting separate LMEs, it sharply decreases, tending to zero. The received results can be used for imitating modeling of training at school and university.

### *References*

1. Velichkovskij B.M. *Kognitivnaja nauka: Osnovy psihologii poznanija* [Cognitive science: bases of psychology of knowledge] V. 1. M.: Akademiya, 2006. 448 p.
2. Zinchenko T.P. *Pamjat' v jeksperimental'noj i kognitivnoj psihologii* [Memory in the experimental and cognitive psychology]. SPb.: Piter, 2002. 320 p.
3. Atkinson R. *Vvedenie v matematicheskiju teoriju obuchenija* [Introduction to mathematical theory of learning] / R. Atkinson, G. Baujer, Je. Kroters. M.: Mir, 1969. 486 p.
4. Bush R., Mosteller F. *Stohasticheskie modeli obuchaemosti* [Stochastic models of learning]. G.: Fizmatgiz, 1962. 484 p.
5. Gibson D., Jakl P. Data challenges of leveraging a simulation to assess learning. West Lake Village, CA. 2013. [http://www.curveshift.com/images/Gibson\\_Jakl\\_data\\_challenges.pdf](http://www.curveshift.com/images/Gibson_Jakl_data_challenges.pdf)
6. Leont'ev L.P., Gohman O.G. *Problemy upravlenija uchebnym processom: matematicheskie modeli* [Problem of the educational process management: Mathematical models]. Riga, 1984. 239 p.
7. Roberts F.S. *Discrete Mathematical Models, with Applications to Social, Biological and Environmental Problems*. Prentice-Hall. 1976. 496 p.
8. Sviridov A.P. *Statisticheskaja teorija obuchenija* [Statistical theory of training]: monograph. M. Izd-vo RSGU, 2009. 570 p.
9. Hunt E. *The Mathematics of Behavior*. New York: Cambridge University Press, 2007. 346 p.
10. Mayer R.V. *Kiberneticheskaja pedagogika: Imitacionnoe modelirovanie processa obuchenija* [Cybernetic pedagogics: Imitating modeling of training process: Monograph]. Glazov, Glazov. gos. ped. in-t, 2014. 141 p.



11. Mayer R.V. Computer–Assisted Simulation Methods of Learning Process. *European Journal of Contemporary Education*. 2015. Vol. 13. Is. 3. pp. 198–212. DOI: 10.13187/ejced.2015.13.198
12. Mayer R.V. Research of the multicomponent pupil’s model on the computer. *Advanced Studies in Science*. London. Volume IV. 2015, pp. 81–95.
13. Mayer R.V. The solution of problems of mathematical learning theory using computer models. *Modern European researches*. 2015. № 3, pp. 113–125.

### **Список литературы**

1. Величковский Б.М. Когнитивная наука: Основы психологии познания: в 2 т. Т. 1. М.: Смысл: Издательский центр «Академия», 2006. 448 с.
2. Зинченко Т.П. Память в экспериментальной и когнитивной психологии. СПб.: Питер, 2002. 320 с.
3. Аткинсон Р., Бауэр Г., Кротерс Э. Введение в математическую теорию обучения. М.: Мир, 1969. 486 с.
4. Буш Р., Мостеллер Ф. Стохастические модели обучаемости. Г.: Физматгиз, 1962. 484 с.
5. Gibson D., Jakl P. Data challenges of leveraging a simulation to assess learning. West Lake Village, CA. 2013. [http://www.curveshift.com/images/Gibson\\_Jakl\\_data\\_challenges.pdf](http://www.curveshift.com/images/Gibson_Jakl_data_challenges.pdf)
6. Леонтьев Л.П., Гохман О.Г. Проблемы управления учебным процессом: математические модели. Рига, 1984. 239 с.
7. Робертс Ф.С. Дискретные математические модели с приложениями к социальным, биологическим и экологическим задачам. М.: Наука, Гл. ред. физ.-мат. лит., 1986. 496 с.
8. Свиридов А.П. Основы статистической теории обучения и контроля знаний. М.: Высшая школа, 1981. 262 с.
9. Hunt E. *The Mathematics of Behavior*. New York: Cambridge University Press, 2007. 346 p.
10. Майер Р.В. Кибернетический подход к исследованию процесса обучения // Практическая психология: Интенсивные методы и тех-

нологии в обучении и развитии личности: сб. науч. ст. Глазов: Глазовск. гос. пед. ин-т, 2013. С. 49–59.

11. Mayer R.V. Computer–Assisted Simulation Methods of Learning Process // *European Journal of Contemporary Education*. 2015. Vol. 13. Is. 3. pp. 198–212. DOI: 10.13187/ejced.2015.13.198
12. Mayer R.V. Research of the multicomponent pupil’s model on the computer // *Advanced Studies in Science*. London. Volume IV. 2015, pp. 81–95.
13. Mayer R.V. The solution of problems of mathematical learning theory using computer models // *Modern European researches*. 2015. № 3, pp. 113–125.

#### DATA ABOUT THE AUTHOR

**Mayer Robert Valerievich**, Doctor of Pedagogical Sciences, Professor of the Department of Physics and Didactics of Physics  
*Glazov Korolenko State Pedagogical Institute*  
*25, Pervomayskya Str., Glazov, Udmurt Republic, 427621, Russian Federation* ORCID: 0000-0001-8166-9299  
*robert\_maier@mail.ru*

#### ДАнные ОБ АВТОРЕ

**Майер Роберт Валерьевич**, доктор педагогических наук, профессор кафедры физики и дидактики физики  
*Глазовский государственный педагогический институт им. В.Г. Короленко*  
*ул. Первомайская, 25, г. Глазов, Удмуртская Республика, 427621, Российская Федерация*  
*robert\_maier@mail.ru*